

DESCRIPTIF

NUMERO	DESIGNATION	NUMERO	DESIGNATION
1	CUVE	16	COMMANDE MECANIQUE
2	RESERVOIR	17	COMMANDE ELECTRIQUE
3	REDUCTEUR	18	CANALISATION D'EAU
4	MOTEUR HYDRAULIQUE	19	ECHELLE
5	SUPPORT POMPE HYDRAULIQUE	20	SUPPORT ROTATION GOULOTTE
6	CHASSIS	21	GOULOTTE FIXE
7	AILE	22	1ERE GOULOTTE
8	POMPE HYDRAULIQUE	23	GALET
9	SYSTÈME PNEUMATIQUE POUR RESERVOIR	24	GOULOTTE EN V
10	RADIATEUR D'HUILE	25	PROTECTION
11	SUPPORT AVANT CUVE	26	GOULOTTE DE CHARGEMENT
12	BARRE ANTI-ENCASTREMENT	27	ANNEAU ETANCHEITE
13	GOULOTTE	28	PROTECTION PLASTIQUE
14	RESERVOIR ADDITIF	29	ANNEAU
15	SUPPORT ARRIERE CUVE	30	COURONNE

CUVE POUR PORTEUR TOUTES MARQUES

3

DE 4 A 15 M3

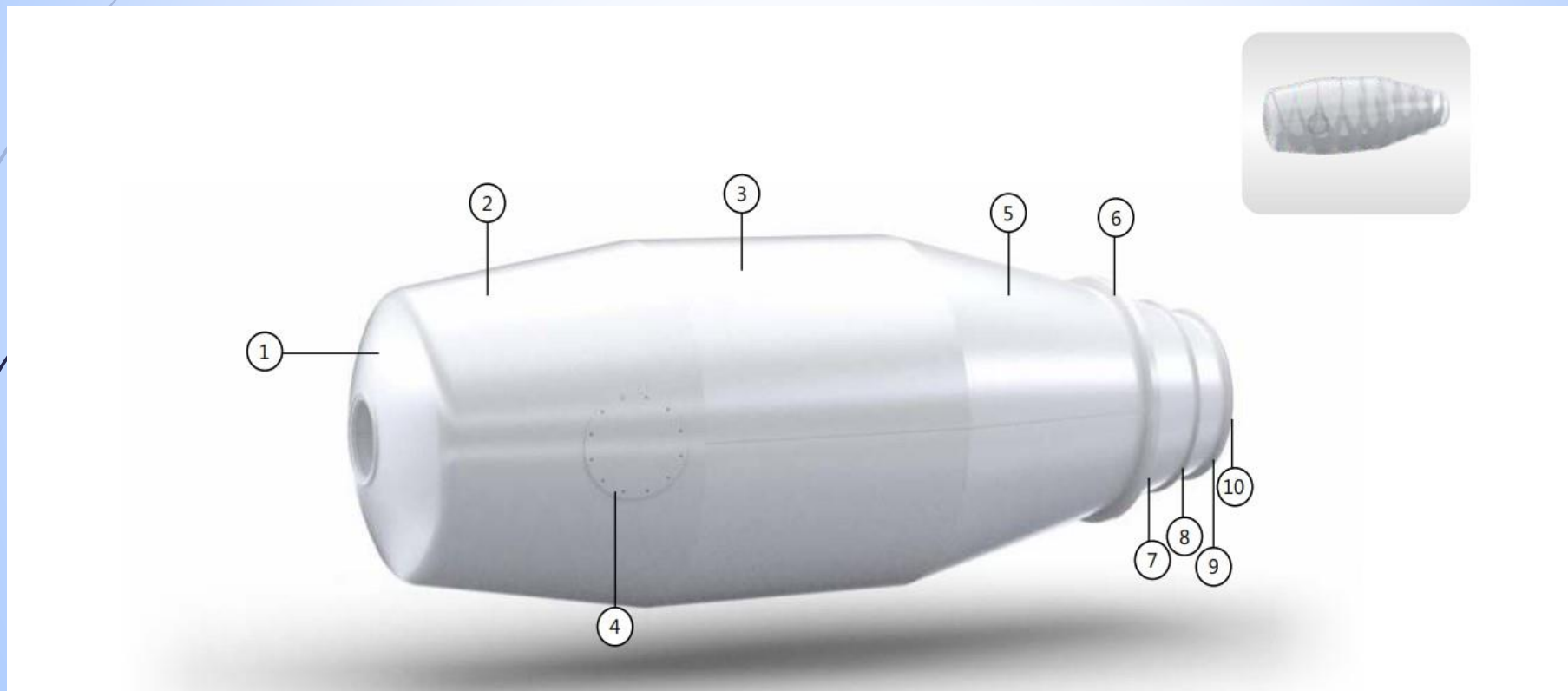

RESERVOIR PRESSURISE OU STANDARD

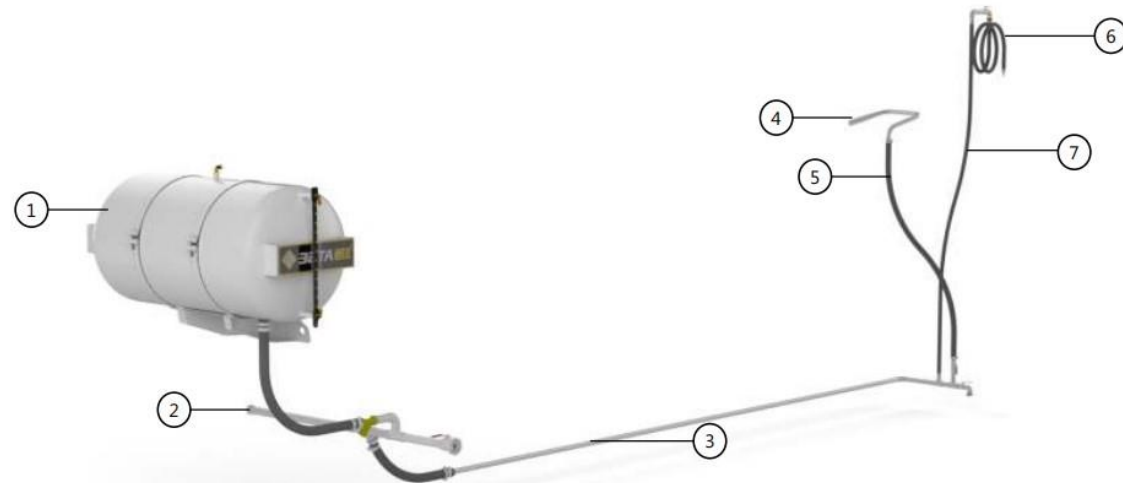

- 1- Réservoir de 350 litres à 1000 litres
- 2- Support
- 3- Jonc
- 4- Sangle
- 5- Jauge

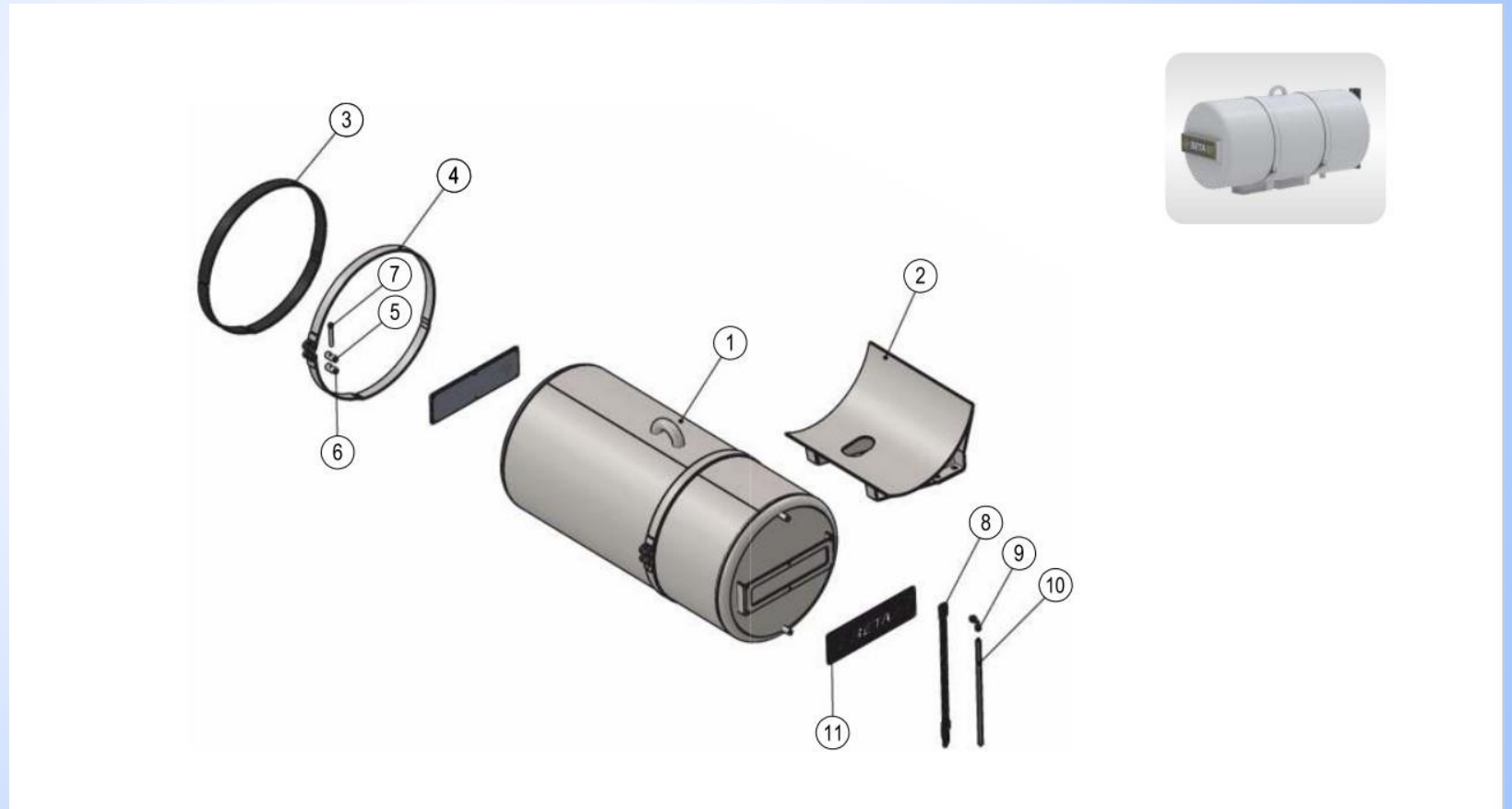

COMPTEUR D'EAU



6

MANOMETRE DE PRESSION



POMPE A EAU

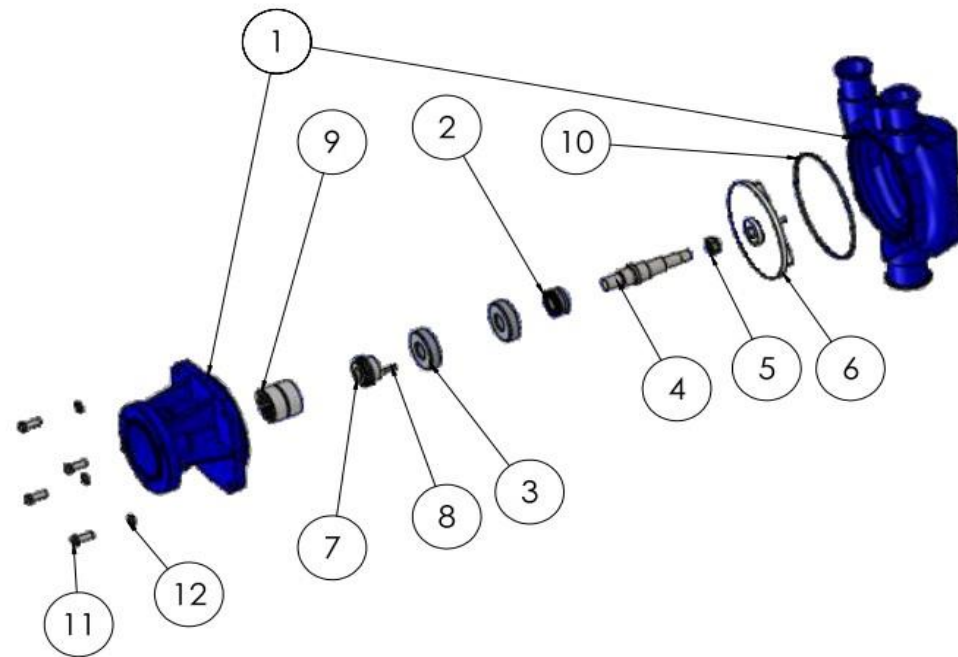

GOULOTTE DE CHARGEMENT

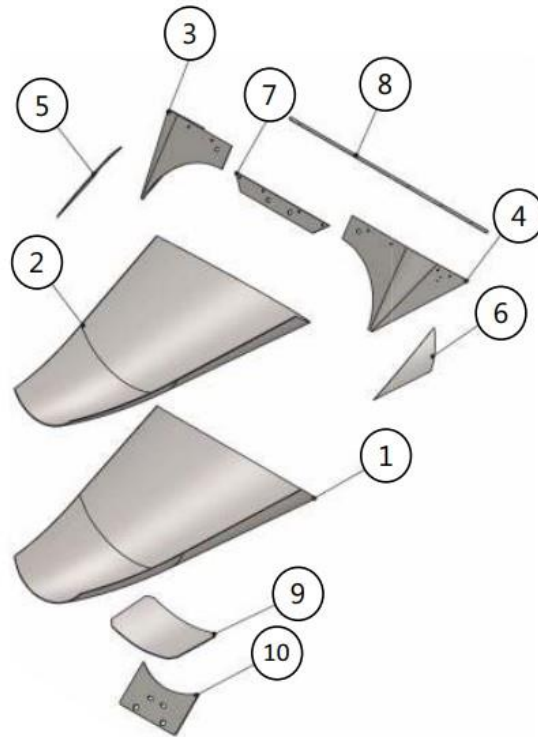

SUPPORT DECHARGEMENT EN V

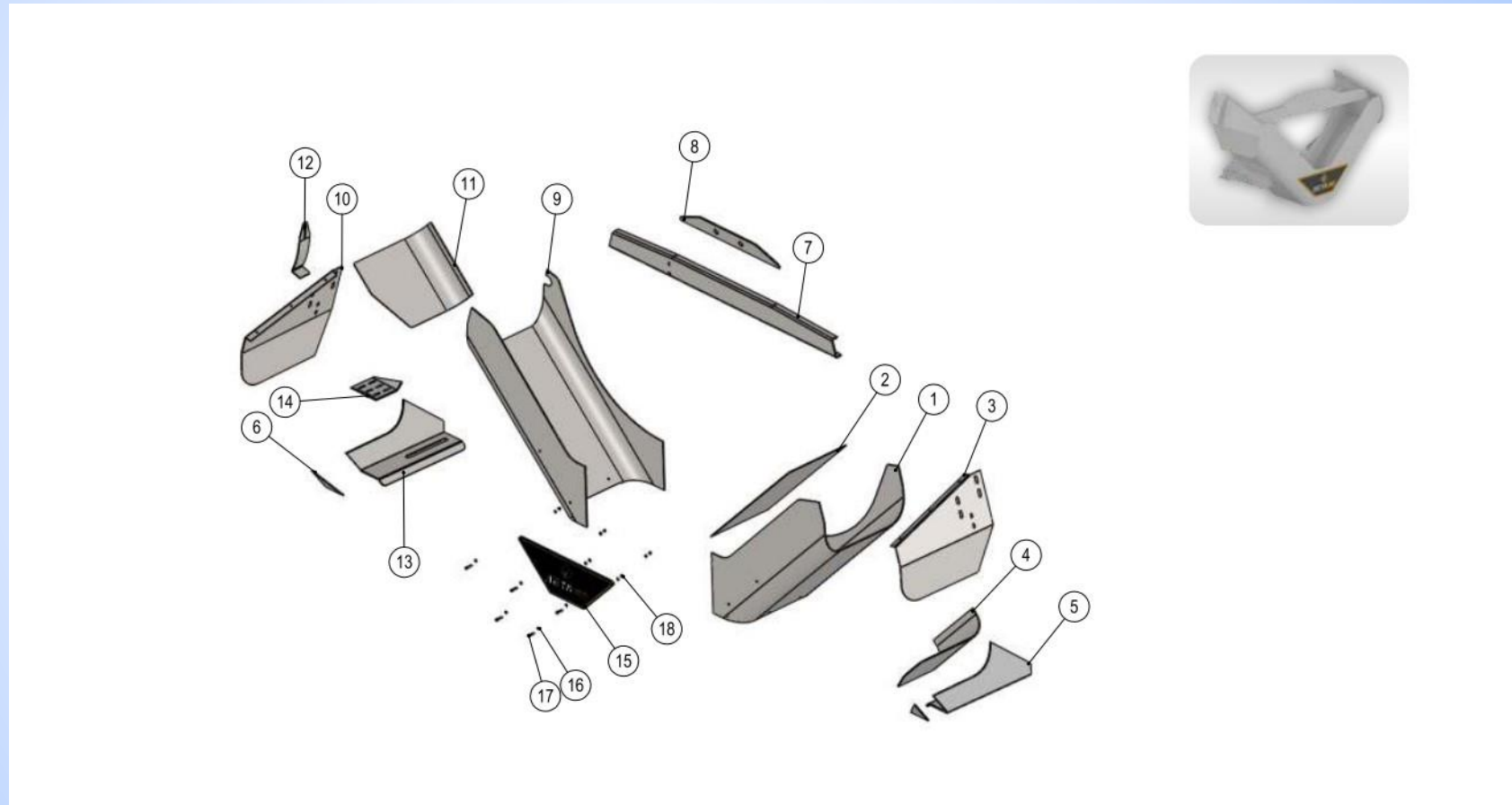

GOULOTTE FIXE

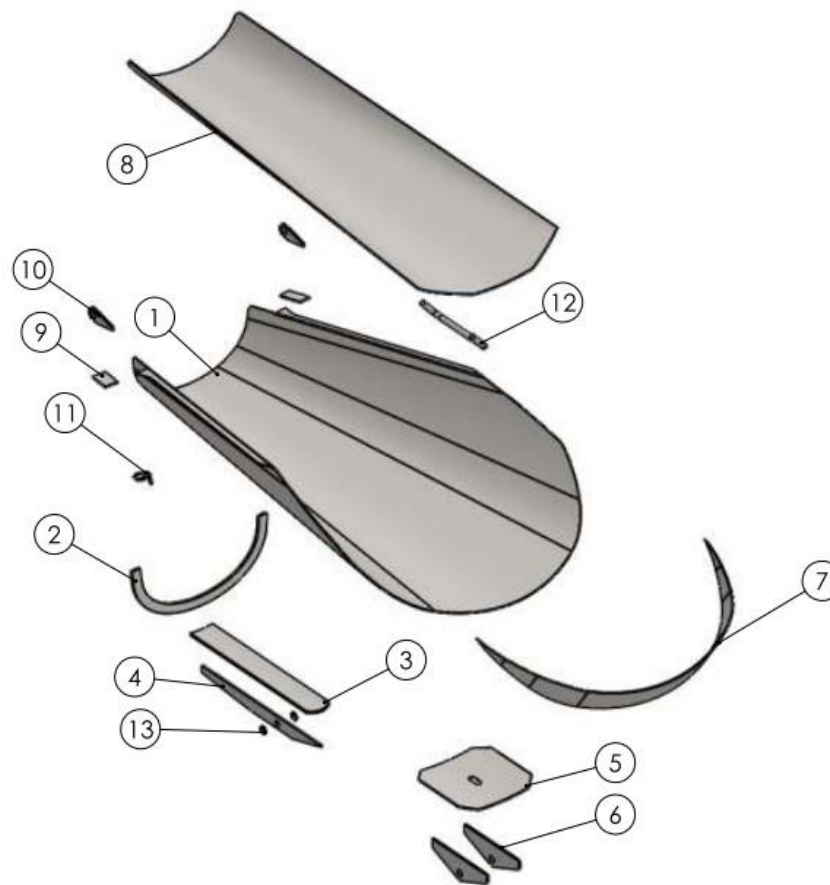

1ERE GOULOTTE

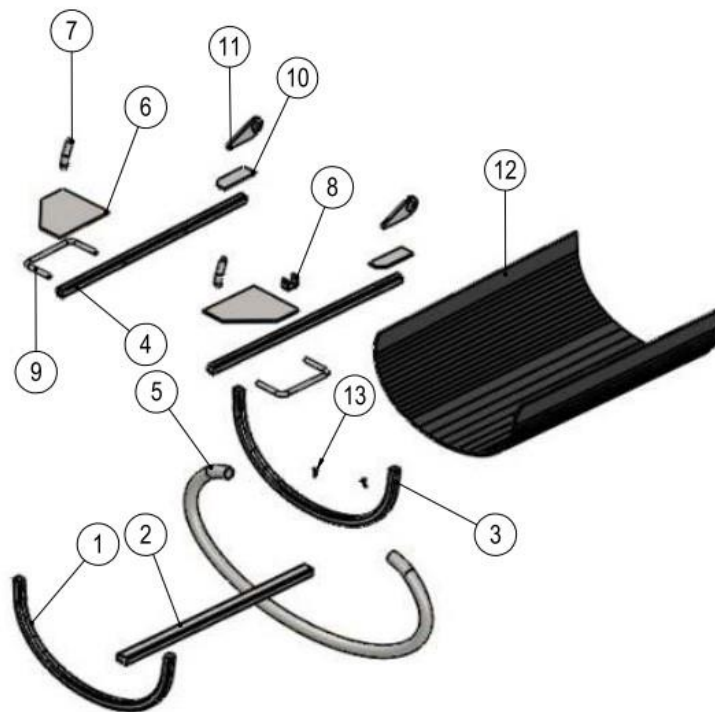

GOULOTTE AMOVIBLE

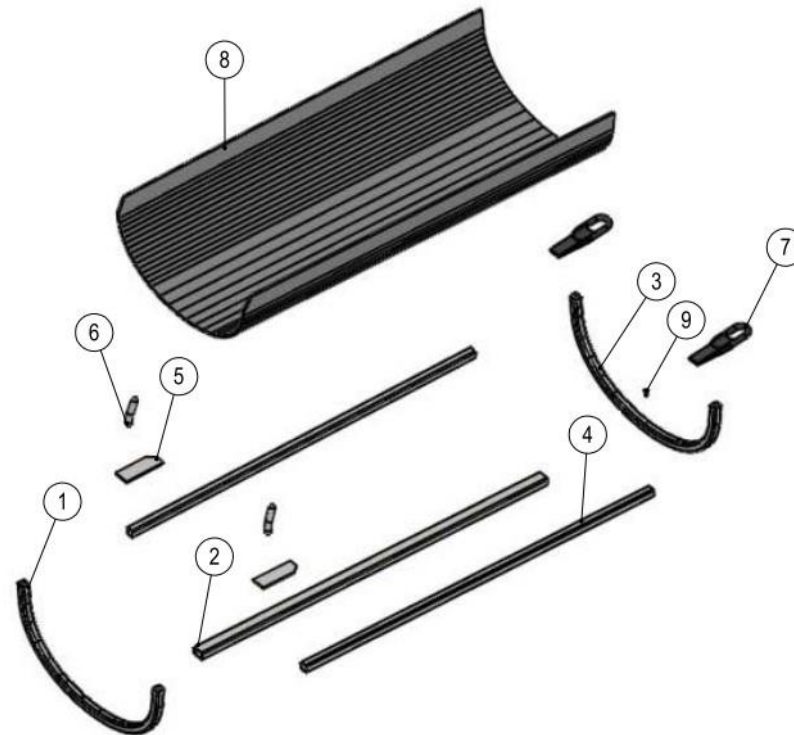
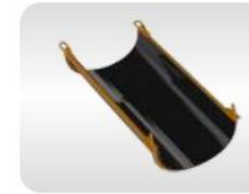

OBTURATEUR

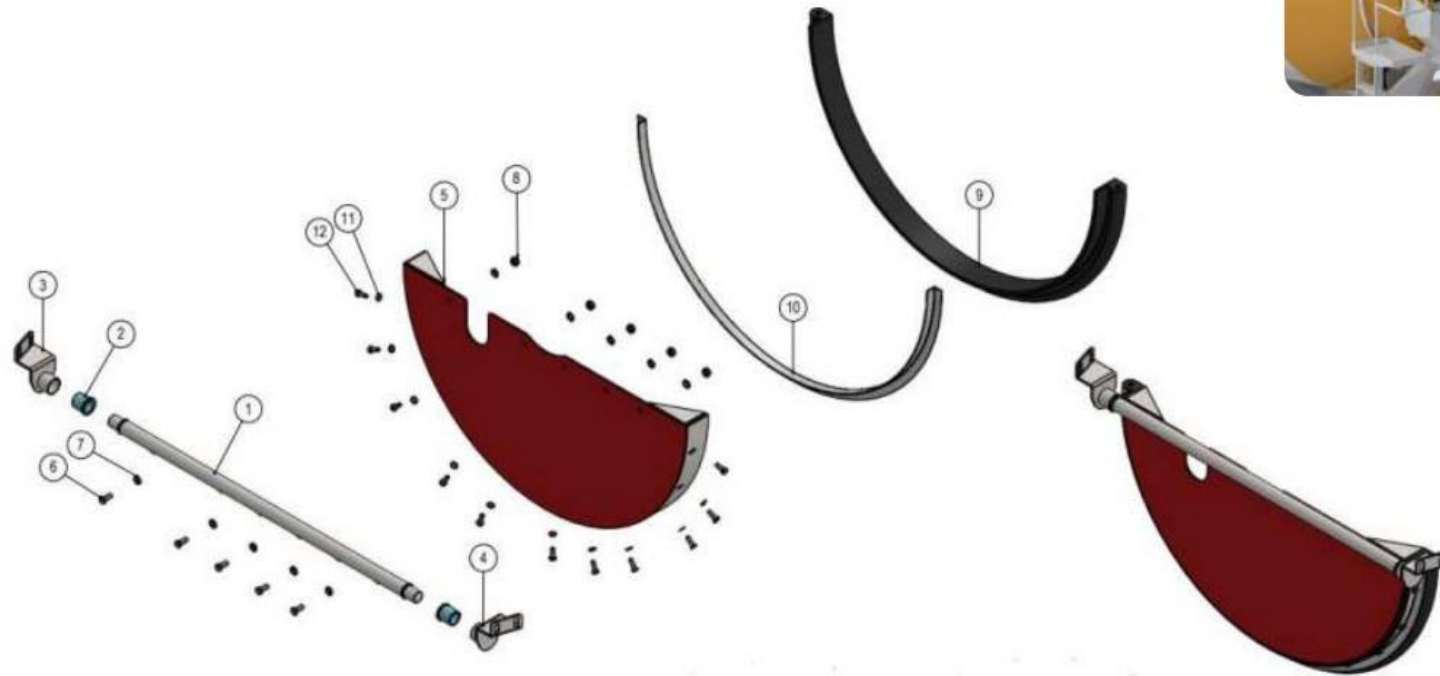

MANIVELLE GOULOTTE



POMPE HYDRAULIQUE POUR GOULOTTE

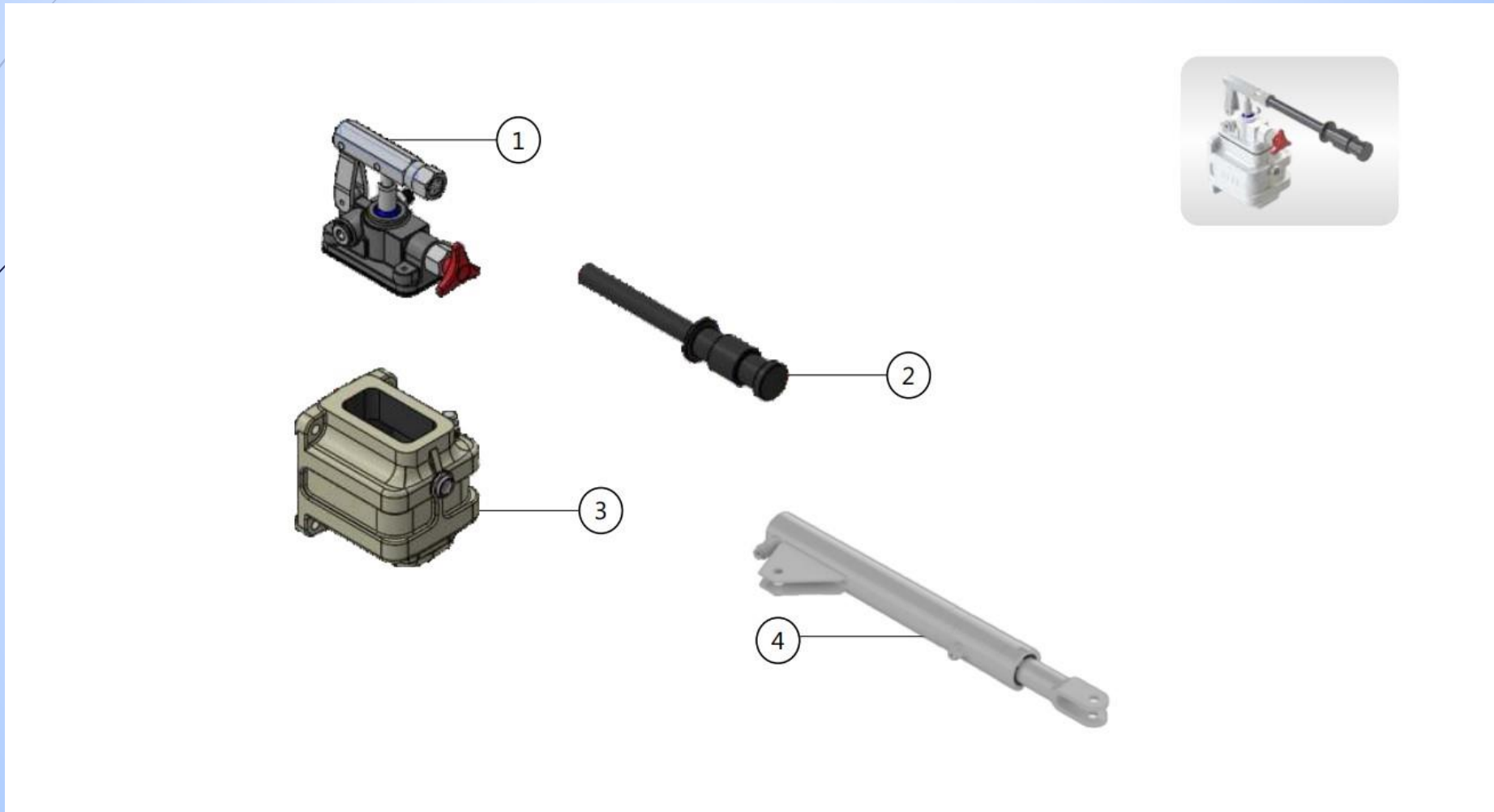

GALET AVEC SUPPORT

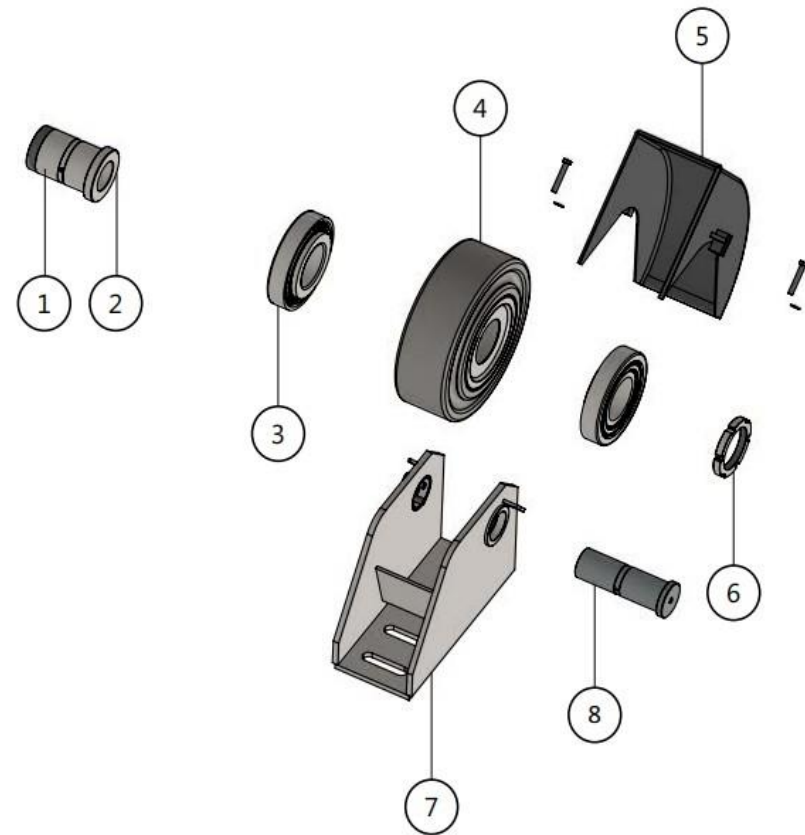

SUPPORT ROTATION GOULOTTE

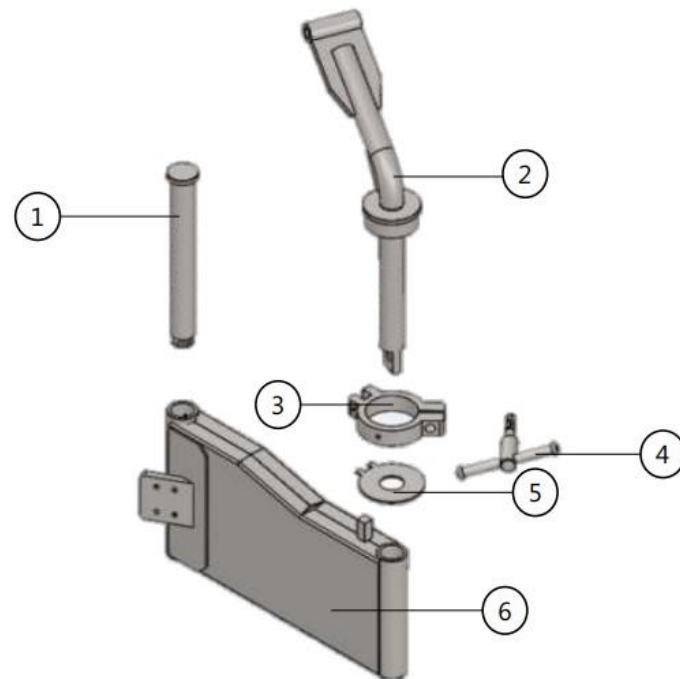

BARRE ANTI-ENCASTREMENT

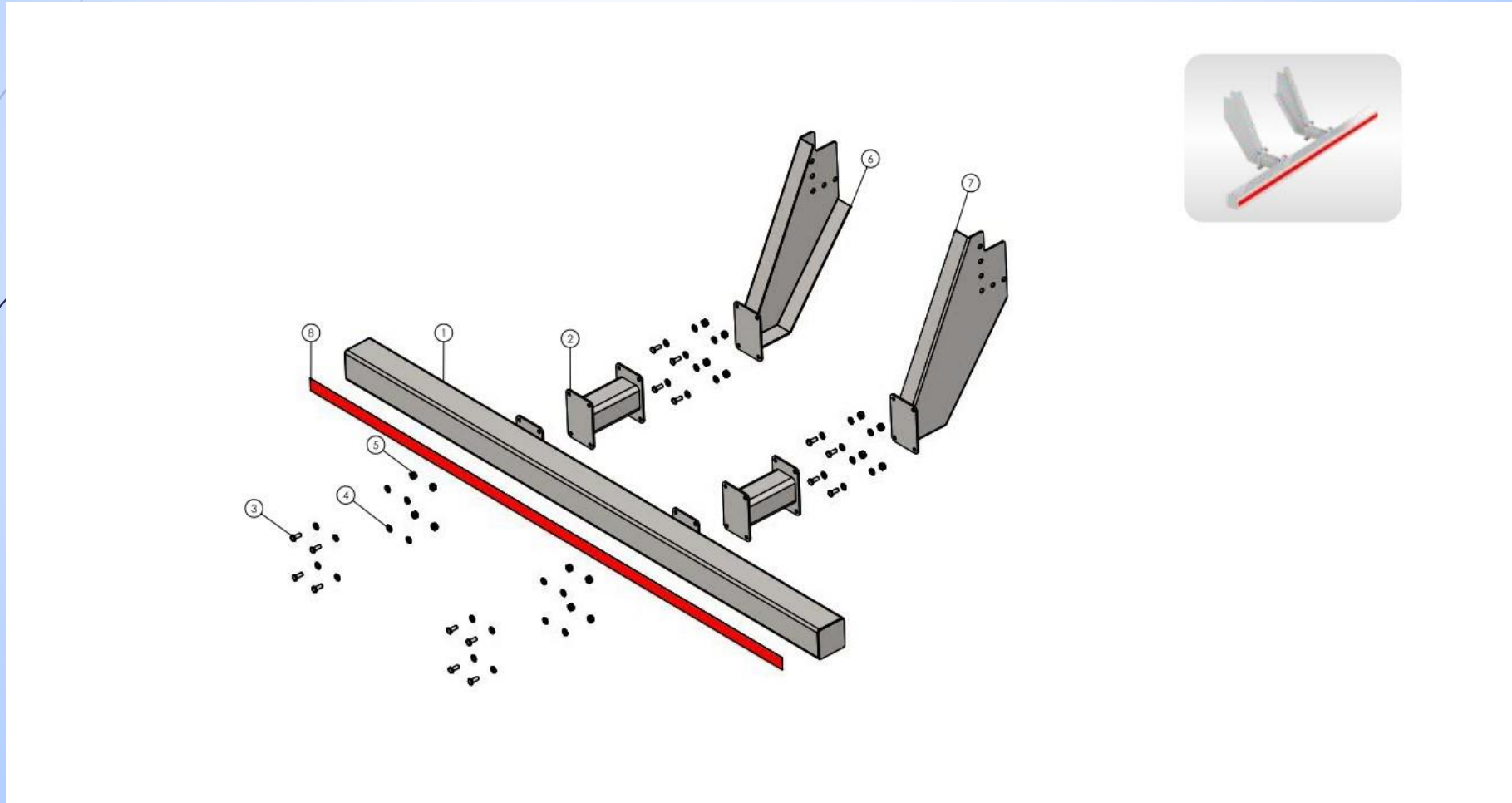

PARE CYCLISTE

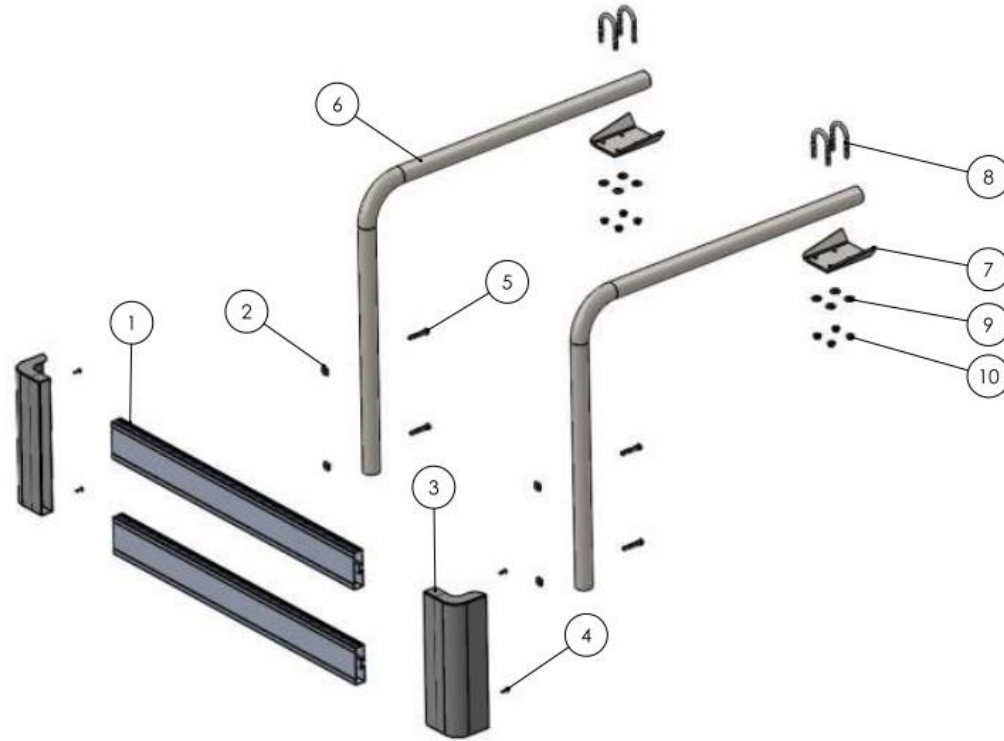

CAPOT MOTEUR

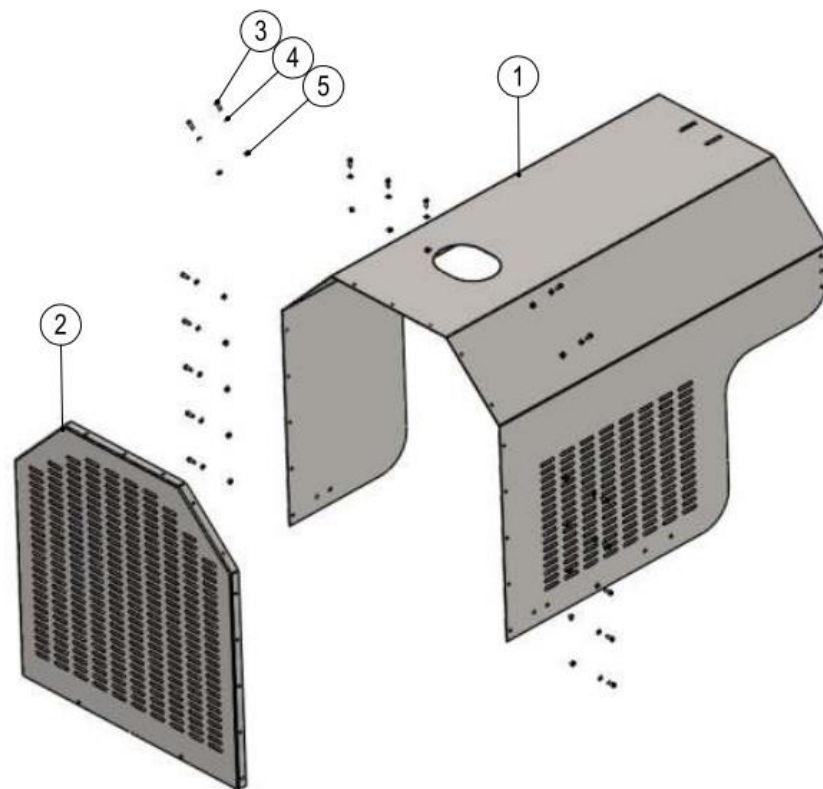

ECHELLE

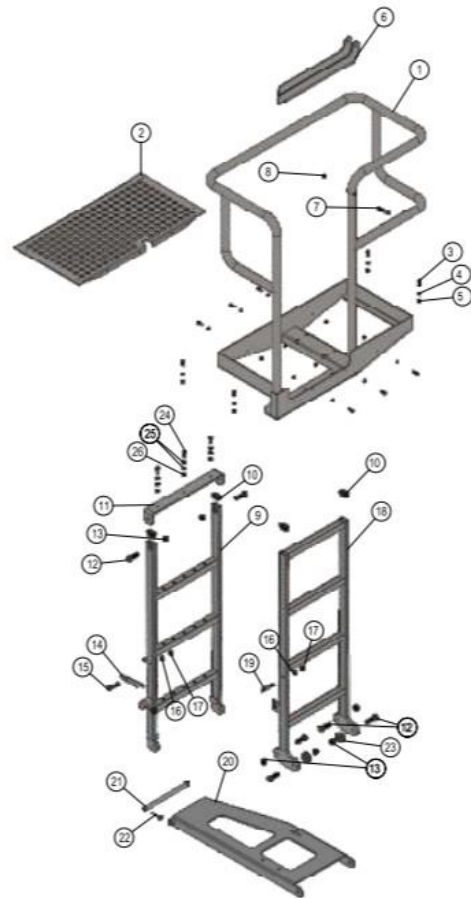

COMMANDE ELECTRIQUE 3 OU 5 BOUTONS

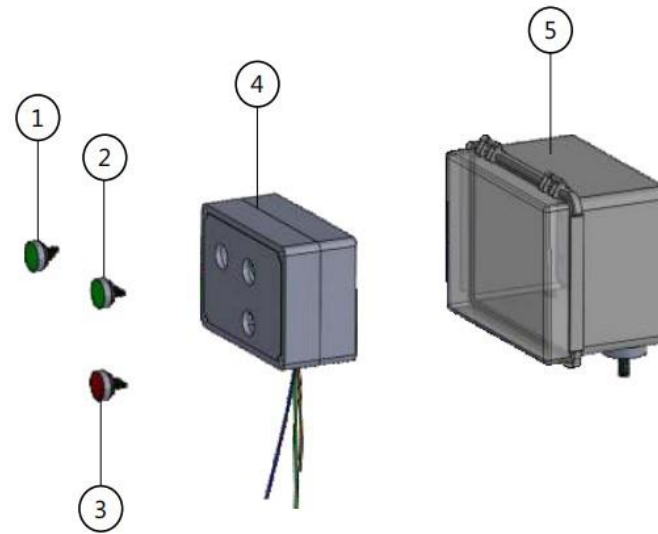

COMMANDE MANUELLE

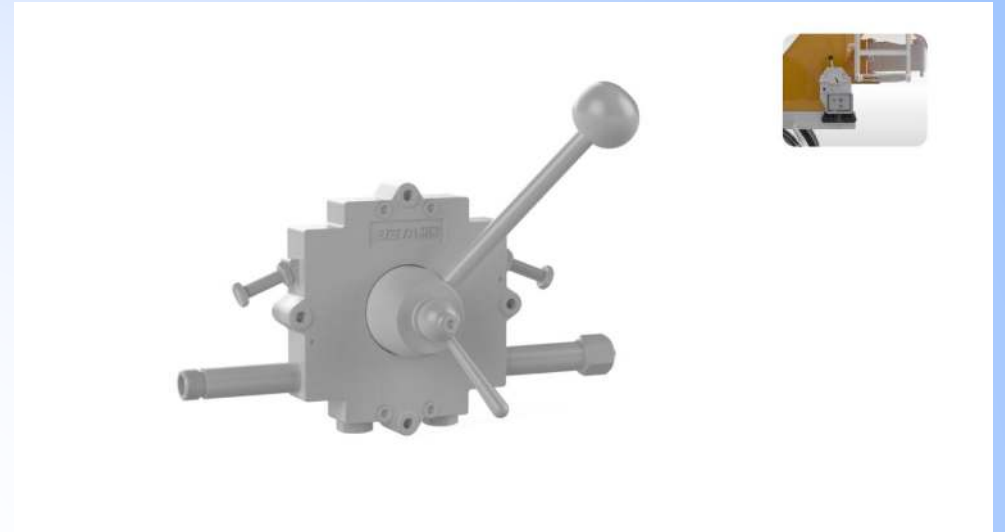

CABLE

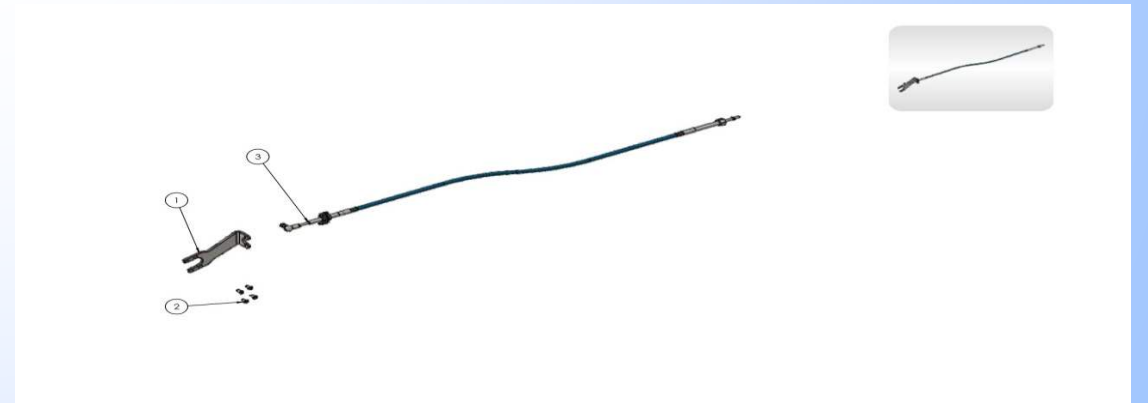

AILE

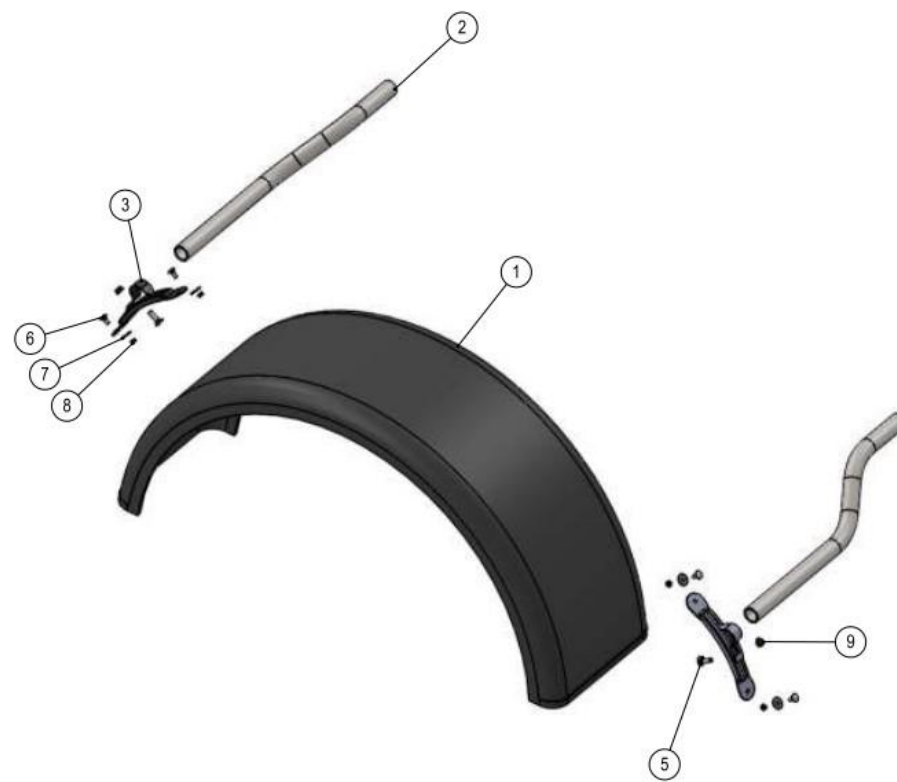

AILE EN ACIER

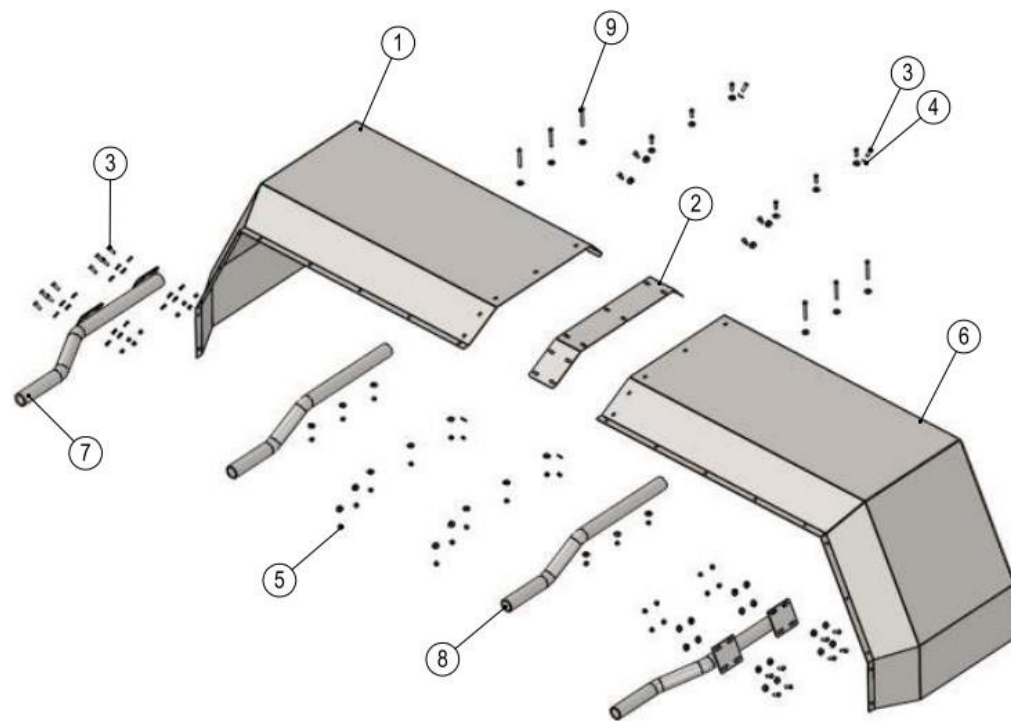

AILE EN ALUMINIUM

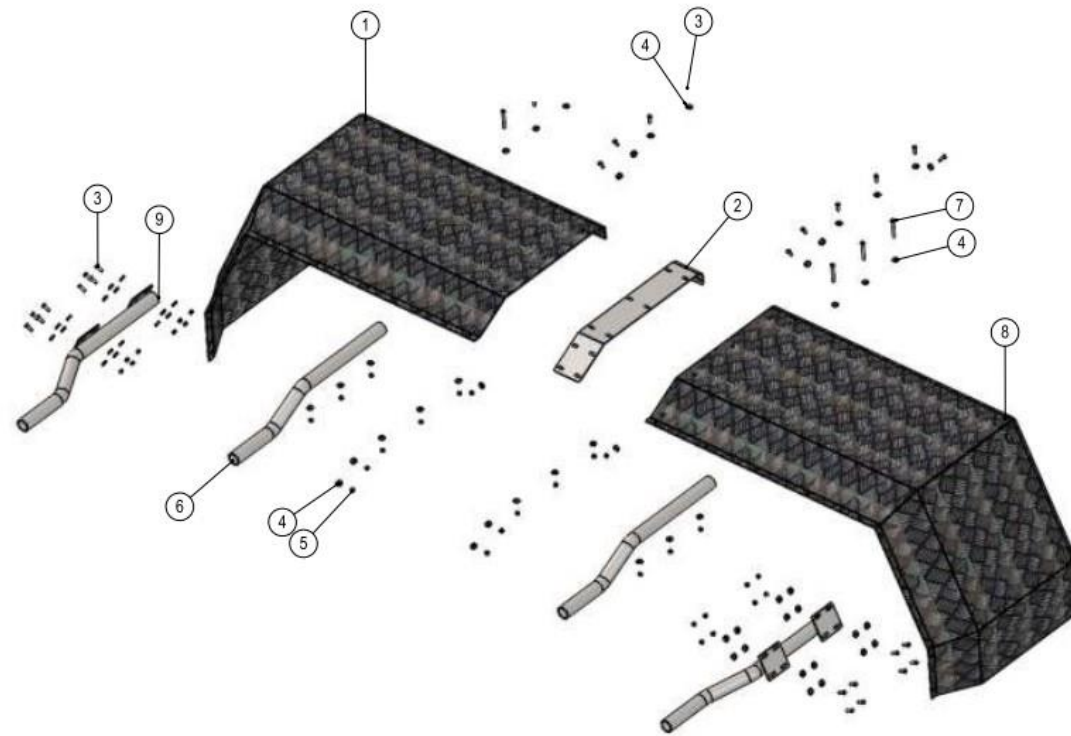

HYDRAULIQUE COMPLET

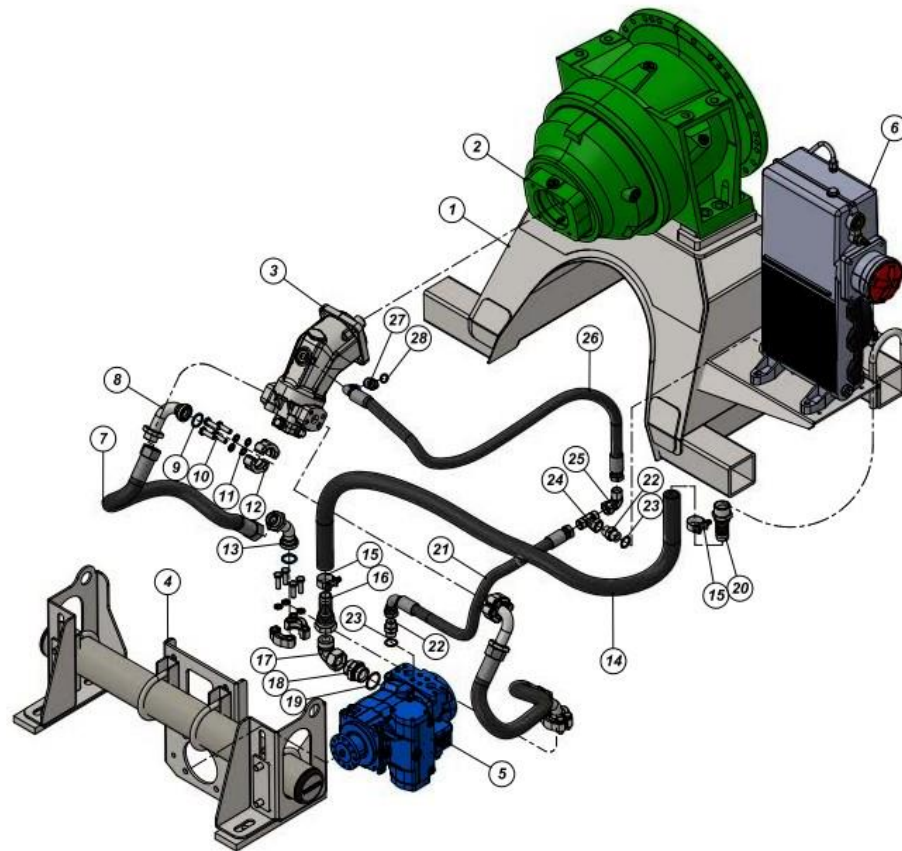

POMPE HYDRAULIQUE



①



②



③

MOTEUR HYDRAULIQUE



①



②



③

REDUCTEUR

1- ZF P5300 OU P7300



1

2- ZF CML 12



2

3- BONFIGLIOLI 580 OU 577

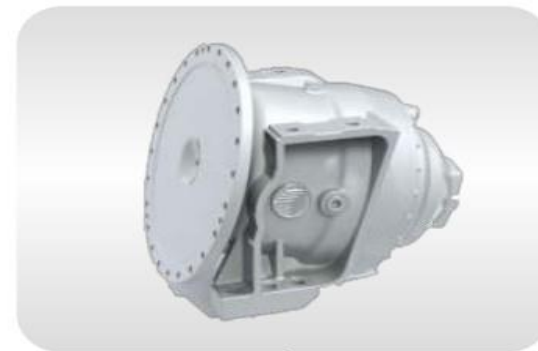

3

REFROIDISSEUR D'HUILE

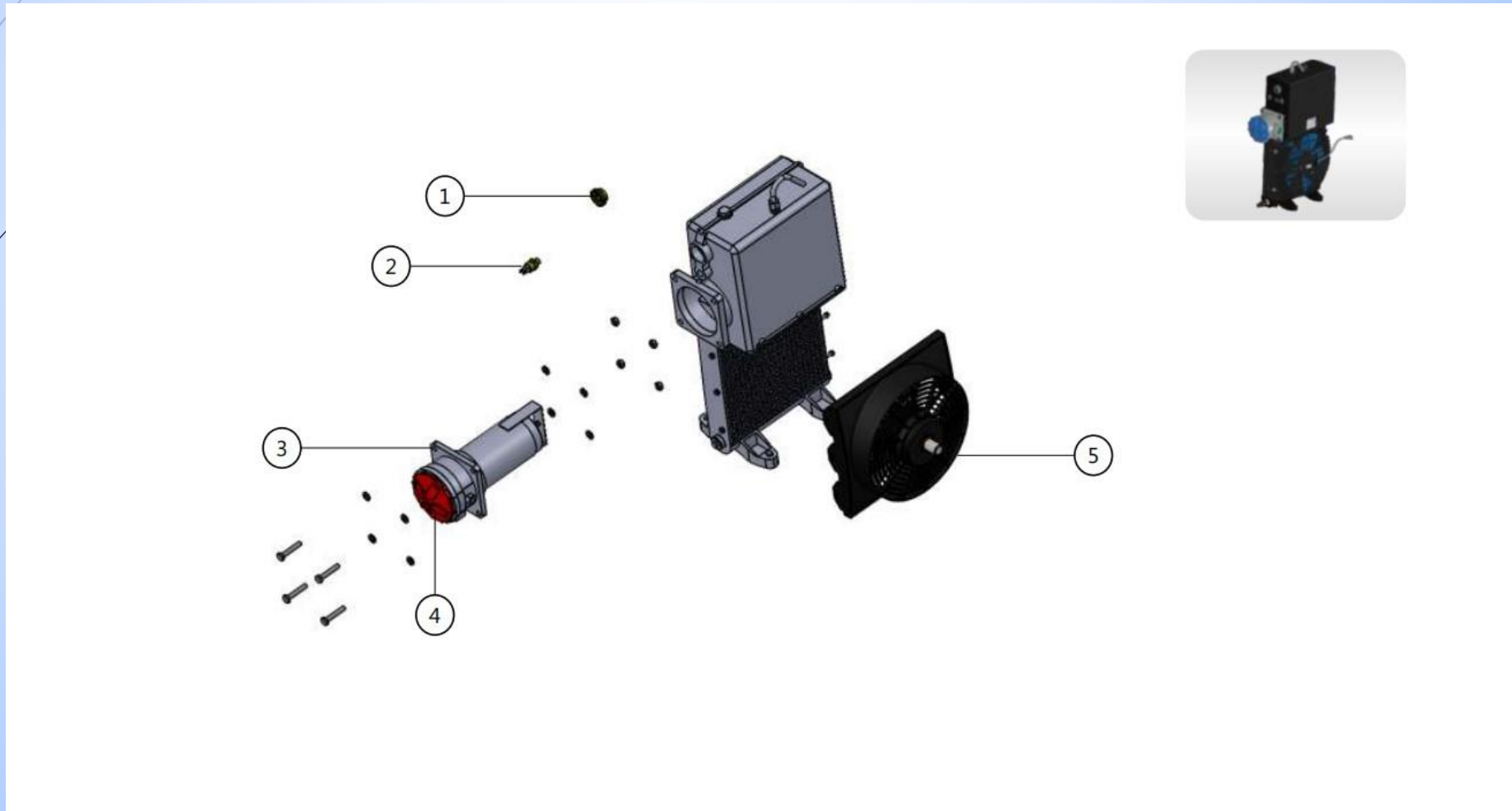

MOTEUR AUXILIAIRE

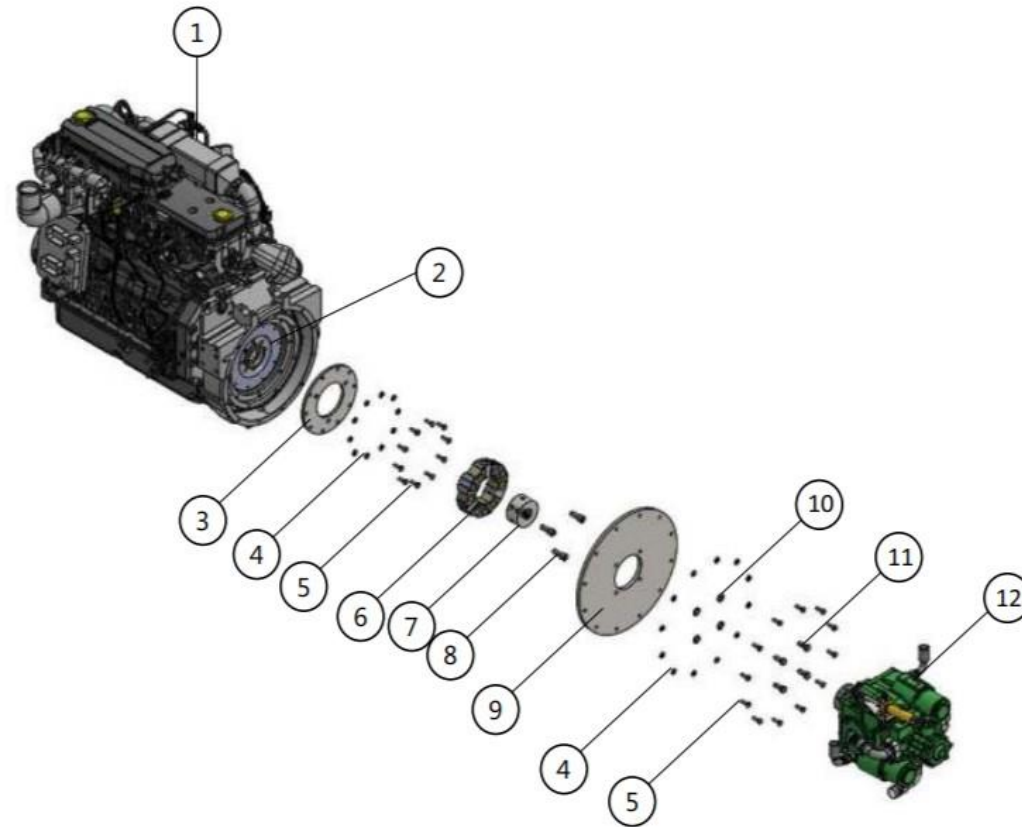

TRANSMISSION



L.TRAILERS

- ▶ Nos pièces détachées sont adaptables sur les toupies béton de marques :
- ▶ Imer, Stetter, Liebherr, CIFA, Betamix
- ▶ N'hésitez à me contacter pour de plus amples renseignements
- ▶ **Chrystèle Lamborot**
- ▶ **06.89.32.56.81**